

DETAIL a

NOTE
 1. 지사의 용접부는 모재 두께의 70% 연속용접할것.
 2. MAIN PLATE 및 I-BEAM의 맞대기 연결부는 서로겹치지 않도록할것.(200MM이상 유지)

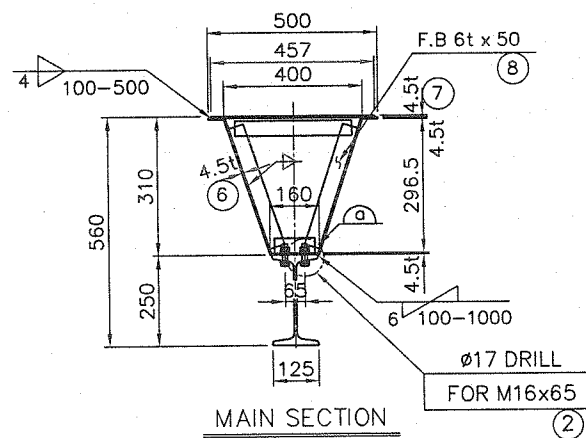
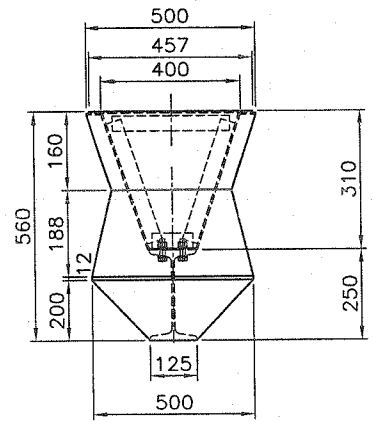
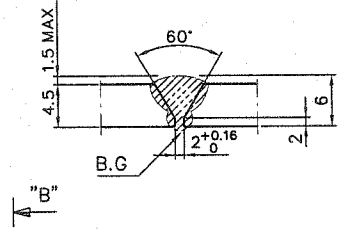
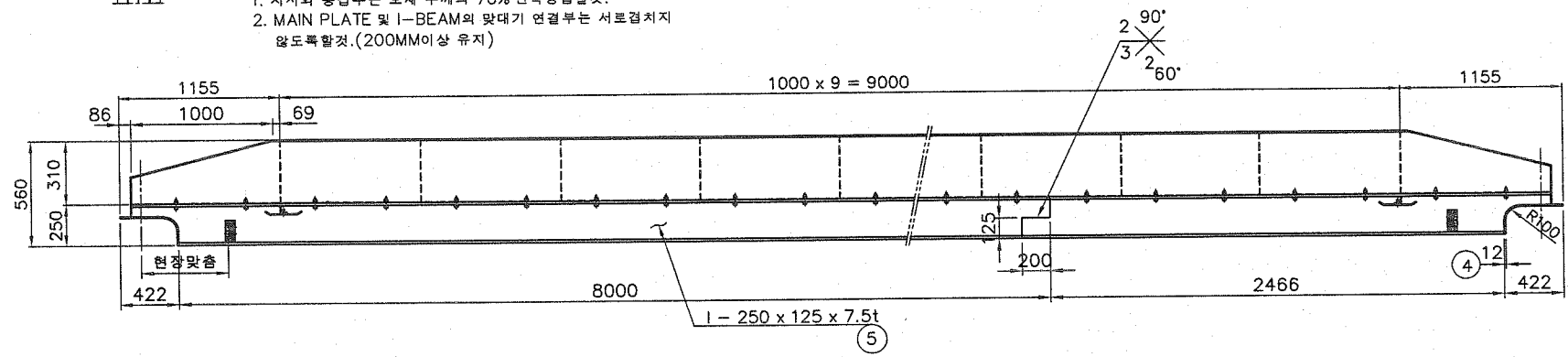

TOTAL WEIGHT : 1060 KG

NO.	DESCRIPTION	MT'L	QTY	WEIGHT KG	REMARK
8	F.B 50x6tX6000	SS400	1.9	27	
7	4.5tX457X11164	SS400	1	180	
6	4.5tX914X11138	SS400	1	360	
5	I-250X125X7.5/12.5t	SS400	1	427	11138L
4	12tX500X610	SS400	2	57	
3	6tX188X500	SS400	2	9	
2	H.T B/N 8T/W 2-P/W	F10T	26		M16x65L
1	H.T B/N 5T/W 2-P/W	F10T	12		M16x65L

NO.	DATE	REVISION	NO.	DATE	REVISION	NOTE
1			1			
2			2			
3			3			

제작사



DRAWN BY: 윤성복
 DESIGNED BY: 김태훈
 CHECKED BY: 김형남
 APPROVED BY: [Signature]

SCALE: N/S
 PROJECT: 2 TON x SPAN 11 M 000

DATE: 2017. 11.
 PROJECT NO.: JD-2-11
 DRAWING NO.: 01A

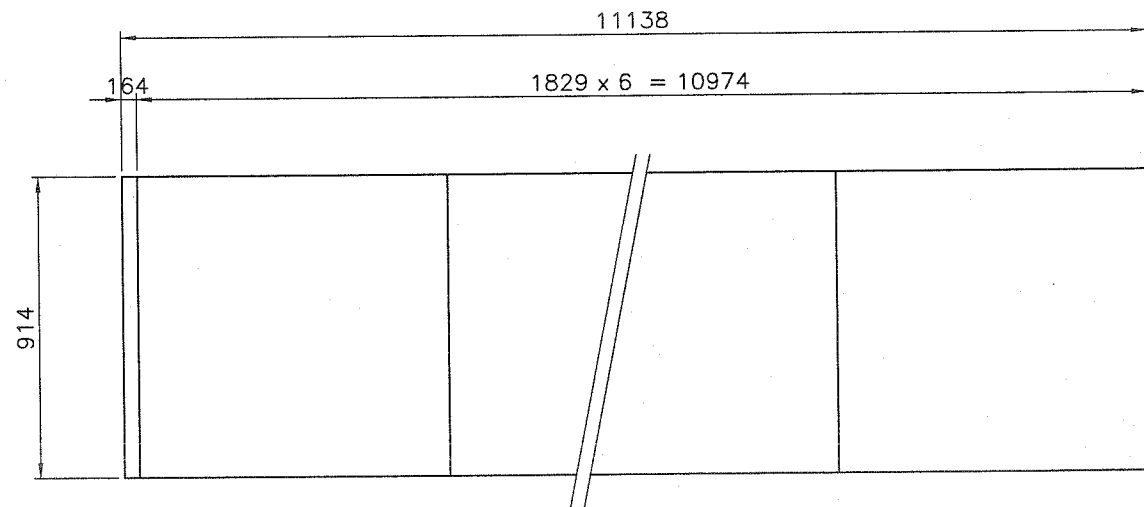
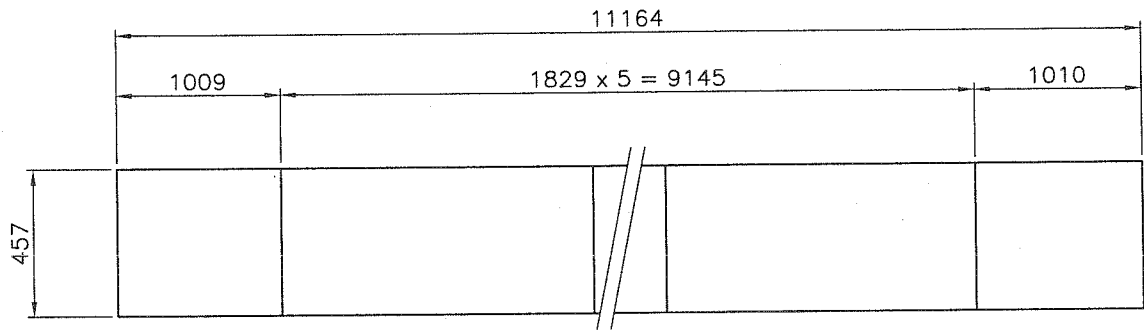

CUTTING PLAN

NO.	DATE	REVISION	NO.	DATE	REVISION	NOTE
1			1			
2			2			
3			3			

제작사



DRAWN BY	윤성복	JK
DESIGNED BY	김석준	J-04
CHECKED BY	김관영	Z-04
APPROVED BY		

SUBJECT	CUTTING PLAN
PROJECT	2 TON x SPAN 11 M 000

SCALE	N/S	DATE	2017. 11.
PROJECT NO.	JD-2-11	DRAWING NO.	01B

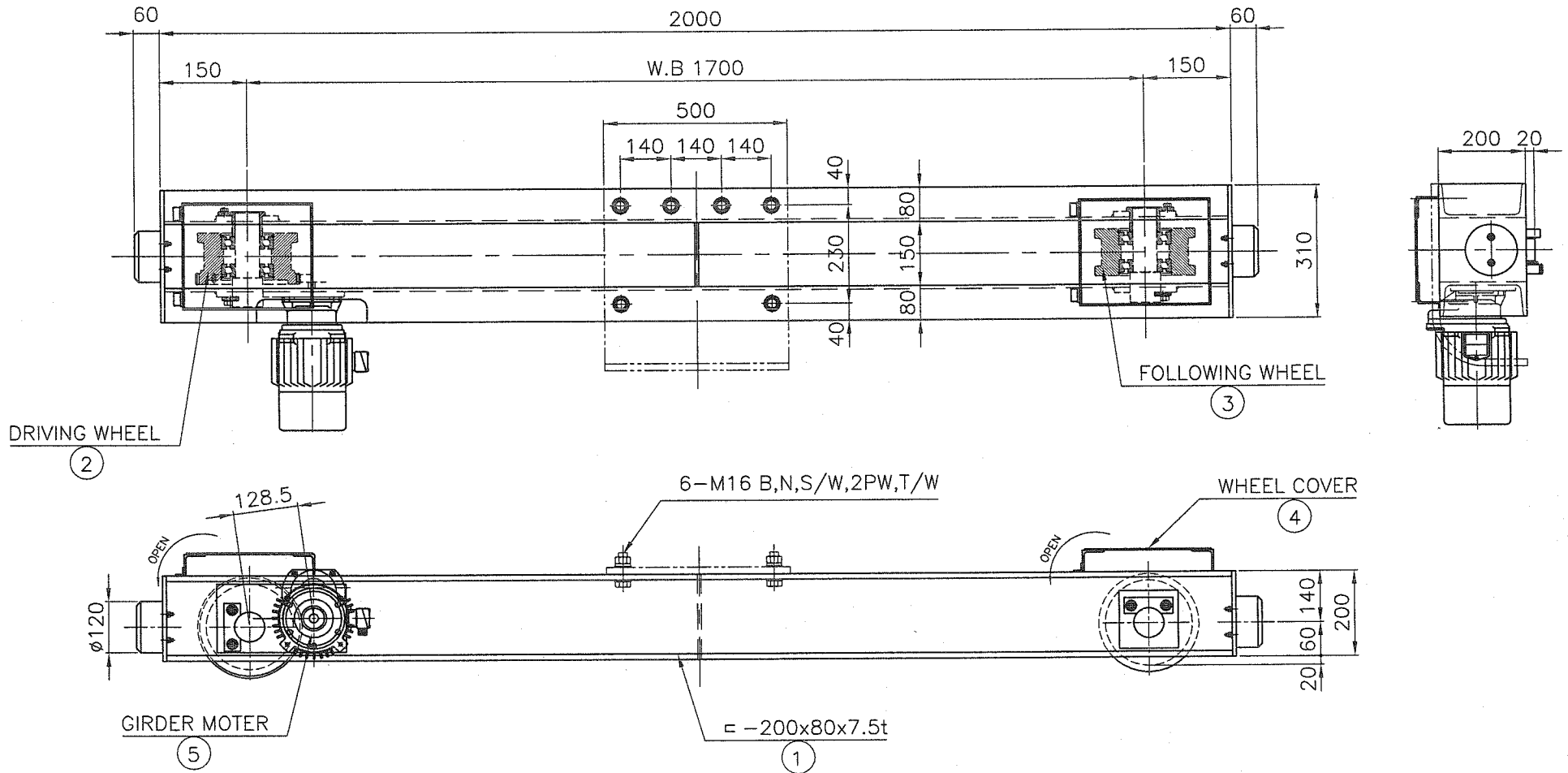

$$V = 1650 \times 3.14 \times 0.16 \times 16 / 48 \times 1 / 16.3 = 17 \text{ m/min}$$

$$(M = 4)$$

NOTE

1. 지시없는 용접부는 양음모재 두께의 70%로 연속용접할것.
2. 절단면은 그라인딩 할것.
3. 거더와 새들을 체결하는 볼트 출은 동시에 가공할것.
4. 볼트의 길이는 너트를 체결하고 나사산이 3산 이상이 남을것.
5. 거더와 체결하는 볼트는 HIGH TENSION BOLT로 사용할것.
6. 거더와 체결하는 새들의 대각편차는 10M당 1mm, 최대 3mm이내일것.

SPECIFICATION		
SPEED	17	M/MIN
MOTOR	0.75	KW x 4 P
POWER SOURCE	AC 3 380 V 60 Hz	
REMARK		

WEIGHT = 230 KG

NO.	DESCRIPTION	MT'L	QTY	WEIGHT KG	REMARK
5	GEARED MOTOR	PUR-	1	30	
4	WHEEL COVER	SS400	2	25	
3	FOLLOWING WHEEL	S45C	1	22	
2	DRIVING WHEEL	S45C	1	26	
1	SADDLE FARMER	SS400	1	127	

NO.	DATE	REVISION	NO.	DATE	REVISION	NOTE
1			1			
2			2			
3			3			

제작사



DRAWN BY 윤성복 /SK
 DESIGNED BY 김태훈 /LKH
 CHECKED BY 김현일 /JLH
 APPROVED BY

SUBJECT 160
 PROJECT SADDLE ASS'Y

SCALE N/S
 DATE 2017. 11.
 PROJECT NO. JD-2-11
 DRAWING NO. 01A